



## DESCRIPTION

Quick-Vac is an integrated valving assembly that can be driven by the PPC2 valve drivers. It is designed to provide a compact and easy to use package to connect the device under test directly to a vacuum pump and shut it off from the PPC2. This allows a much better vacuum to be applied to the test when seeking to set zero absolute than can be obtained through the PPC2 since the PPC2 includes a complex pneumatic circuit with small orifices and the down control valves are exposed to a constant flow from pressure regulators.

## GENERAL INSTALLATION (see reverse page for schematic)

The Quick-Vac system is designed to be installed near the PPC2's rear panel between the pressure supply and pressure test connections.

- ❶ Make the supply connection. The Quick-Vac system includes a pneumatically actuated valve that requires a pressure supply of 350 to 700 kPa (50 to 100 psi). This supply can be provided using the same supply that is used for the PPC2 or separately.
- ❷ If you want to use the same supply for the Quick-Vac and for the PPC2, connect the supply to the Quick-Vac "SUPPLY" connection (1/8" NPT F). Then make a connection between the Quick-Vac "PPC SUPPLY" connection (1/8" NPT F) and the PPC2 "SUPPLY" connection (1/8" NPT F).
- ❸ If you want to use a separate supply (for example shop air) to the Quick-Vac, connect that supply directly to the Quick-Vac supply connection and plug the Quick-Vac "PPC SUPPLY" connection.
- ❹ Connect the PPC2 "Test" connection (1/8" NPT F) to the Quick-Vac "PPC TEST" connection (1/8" NPT F).
- ❺ Connect the Quick-Vac "PPC VALVE DRIVER" connection (electrical connector) to the PPC2 "DRIVER" connection.
- ❻ Connect your vacuum pump and vacuum gauge to the Quick-Vac "VACUUM" connection (1/4" NPT F).
- ❼ Connect to the device under test to the Quick-Vac "TEST" connection (1/8" NPT F).

## USING QUICK-VAC (see schematic on reverse page)

### Quick-Vac Includes Two Isolation Valves

#### Valve A (Vacuum Isolation Valve)

Normally closed pneumatically actuated valve. Actuated by normally closed solenoid valve A1.

#### Valve B (PPC2 Isolation Valve)

Normally open solenoid valve.

### Solenoid Valves

Solenoid valves A1 and B are actuated by the valve drivers of PPC2 (see PPC2 valve driver option in PPC2 manual). Solenoid valve A1 is on PPC2 valve driver 7 and solenoid valve B is on PPC2 valve driver 8.

- ❶ To apply test pressure defined by the PPC2 to the device under test: Do not actuate any PPC2 valve drivers.
- ❷ To isolate PPC2 from the device under test and connect the device under test to the vacuum pump: Actuate PPC2 valve drivers 7 and 8.

• Quick-Vac should only be operated when the pressure applied to the test is atmospheric or below.

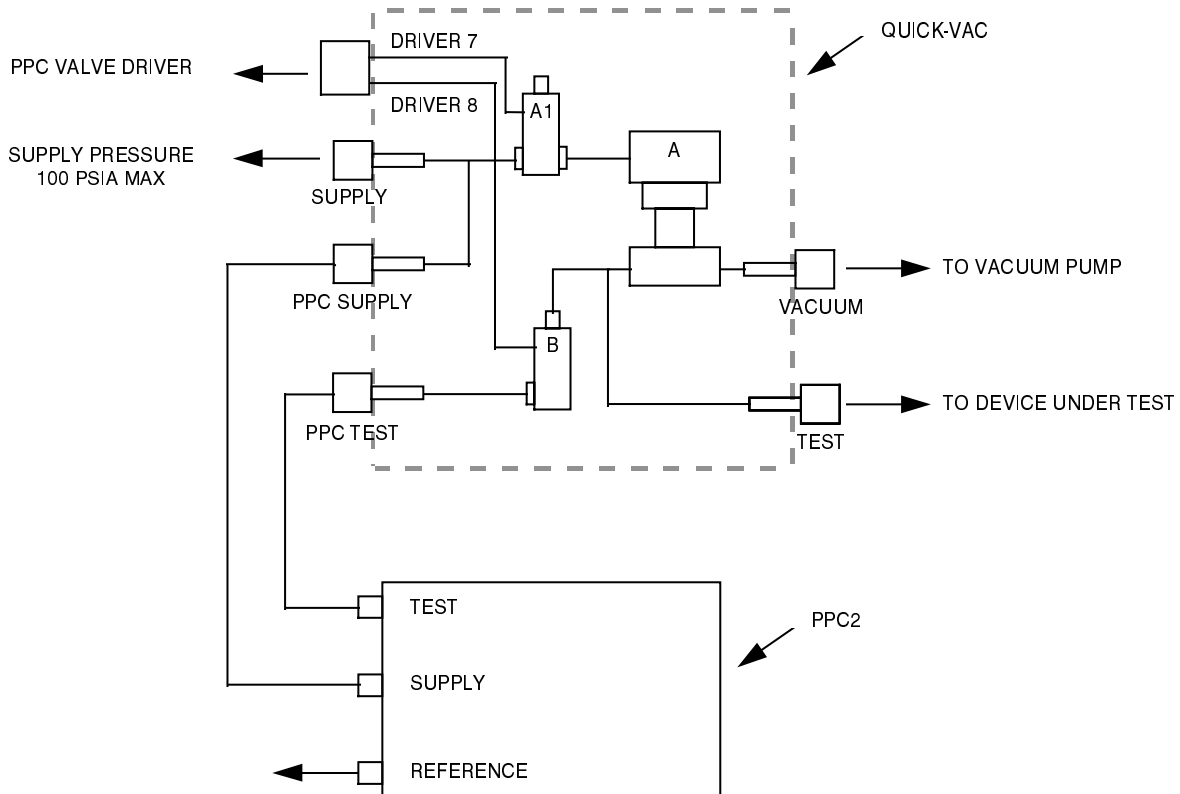

PPC2 is a trademark of DH Instruments, Inc.