



INTERCONNECTIONS KIT, P/N 401699, INCLUDES

QTY	PART NO	FIGURE CALLOUT	DESCRIPTION
1	401697	N/A	Dual Volume Unit (DVU)
1	101450-Z	1	Tubing, PFA, 1/4 in. x 160 cm
2	103279	2	Adaptor, 1/4 in. tube x O-seal 1/8 in. NPT M
4	101477	3	Adaptor, 1/4 in. tube x 1/4 in. NPT M
2	101985	4	Union, 4P
2	101487	5	Tee, 1/4 in. tube
2	101482	6	Adaptor, 1/4 in. tube x 1/4 in. NPT F

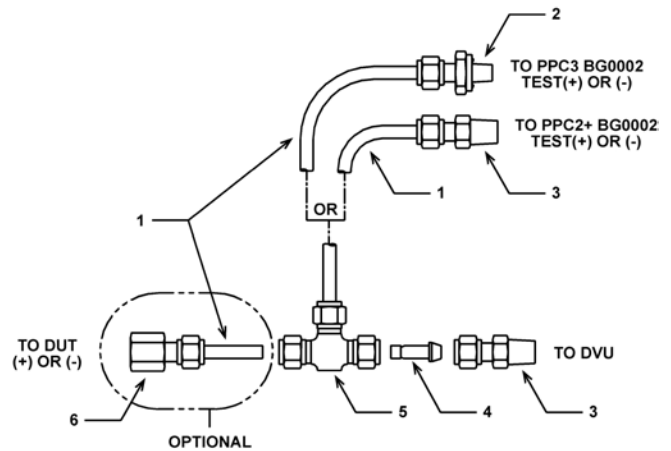

Figure 1 Interconnections Kit

TO INSTALL THE DUAL VOLUME UNIT (DVU)

- Identify a location for the DVU™ that minimizes the length of tubing between the DVU connections and the PPC BG0002™ TEST(+) and TEST(-) ports. The PPC BG0002 and the DVU are designed to stack one on top of the other. The DVU may be rack mounted using the rack mount kit (P/N 400440). Recommended configurations are for the PPC and DVU to be stacked directly one on top of the other or with their rear panels face to face.

TO CONNECT THE DVU AND PPC BG0002



You will be making and connecting two identical assemblies, one for the TEST(+) port and one for the TEST(-) port.

- Install a union (4) into a 1/4 in. tube x 1/4 in. NPT M adaptor (3) (do this twice). Screw the 1/4 in. NPT M end of the adaptors into the two ports of the DVU using Teflon® tape as a sealer.

- Install a 1/4 in. tube tee (5) onto each of the union/adaptor assemblies that were just installed into the DVU ports in Step 1. Orient the tee considering the connection to the PPC BG0002 (schematic above is for PPC stacked on top of the DVU).

- Install the appropriate adaptors onto the PPC BG0002 TEST(+) and TEST(-) ports:

For PPC3™ Install the 1/4 in. tube x O-seal 1/8 in. NPT M (2).

For PPC2+™ Install the 1/4 in. tube x 1/4 in. NPT M adaptor (3) using Teflon tape as a sealer.

- Cut lengths of PFA tubing as needed to connect the 1/4 in. tube tee to the adaptors on the PPC TEST ports. Take care that the cut is at a right angle to the tube and only cut the length needed.
- Optional for a connection "For DUT" of 1/4 in. NPT M rather than 1/4 in. tube:

- Cut a small length of PFA tubing to use as a union between the 1/4 in. tube tee (5) and the 1/4 in. tube x 1/4 in. NPT F adaptor (6) (see schematic above).

DVU, PPC, PPC2+, PPC3, and PPC BG0002 are trademarks, registered and otherwise, of DH Instruments, Inc.
Teflon® is a registered trademark of E.I. du Pont de Nemours and Company.